

# PMC Panel Mount Power Supply

## 24V 100W 1 Phase / PMC-24V100W1A□

# PMC



### Highlights & Features

- Universal AC input range
- Power will not de-rate for the entire input voltage range
- Full corrosion resistant aluminium casing
- High MTBF > 700,000 hrs. as per Telcordia SR-332
- Safety approval according to IEC/EN/UL 60950-1
- Also available: IP20 and Front Face connectors

### Safety Standards



CB Certified for worldwide use

**Model Number:** PMC-24V100W1A□  
**Unit Weight:** 0.41 kg (0.90 lb)  
**Dimensions (L x W x D):** 158 x 97 x 38 mm  
 (6.22 x 3.82 x 1.5 inch)

### General Description

The new Panel Mount Power Supply is the latest offering from one of the world's largest power supply manufacturers and solution providers - Delta. The product range offers a nominal output voltage of 24V, a wide temperature range from -10°C to +70°C and a highly dependable minimum holdup time. The state-of-the-art design is made to withstand harsh industrial environments. What makes the product stands out from the crowd is its lightweight full aluminum body design which can withstand shock and vibration according to IEC 60068-2-6. Delta's Panel Mount Power Supply also offers overvoltage and overload protection. Using a wide input voltage range design, it is compatible worldwide. The input also includes DC operating voltage from 125-375Vdc. Best of all, this excellent design and quality does not come with a big price tag.

### Model Information

#### PMC Panel Mount Power Supply

Model Number	Input Voltage Range	Rated Output Voltage	Rated Output Current
PMC-24V100W1A□	85-264Vac (125-375Vdc)	24Vdc	4.17A

### Model Numbering

PM	C –	24V	100W	1	A	□
Panel Mount	Product Type C – Enclosed	Output Voltage	Output Power	Single Phase	No PFC	Connector Type A – Terminal Block J – IP20 Terminal Block* L – Front Face*

\*Options

# PMC Panel Mount Power Supply

## 24V 100W 1 Phase / PMC-24V100W1A□

### Specifications

#### Input Ratings / Characteristics

Nominal Input Voltage	100-240Vac
Input Voltage Range	85-264Vac
Nominal Input Frequency	50-60Hz
Input Frequency Range	47-63Hz
Nominal DC Input Voltage*	125-250Vdc
DC Input Voltage Range*	125-375Vdc
Input Current	< 2.0A @ 115Vac, < 1.1A @ 230Vac
Efficiency at 100% Load	> 86% @ 115Vac & 230Vac
Max Inrush Current (Cold Start)	< 50A @ 115Vac, < 100A @ 230Vac
Leakage Current	< 1mA @ 240Vac

\* Safety approval according to IEC/EN/UL 60950-1.

#### Output Ratings / Characteristics\*\*

Nominal Output Voltage	24Vdc
Factory Set Point Tolerance	24Vdc $\pm$ 2%
Output Voltage Adjustment Range	22-28Vdc
Output Current	4.17A (100W max.)
Output Power	100W
Line Regulation	< 0.5% typ. (@ 85-264Vac input, 100% load)
Load Regulation	< 1% typ. (@ 85-264Vac input, 0-100% load)
PARD*** (20MHz)	< 150mVpp
Rise Time	< 30ms @ nominal input (100% load)
Start-up Time	< 1000ms @ nominal input (100% load)
Hold-up Time	> 15ms @ 115Vac, > 90ms @ 230Vac (100% load)
Dynamic Response (Overshoot & Undershoot O/P Voltage)	$\pm$ 5% @ 85-264Vac input, 0-100% load (Slew Rate: 0.1A/ $\mu$ S, 50% duty cycle @ 5Hz to 100Hz)
Start-up with Capacitive Loads	8,000 $\mu$ F Max

\*\*For power de-rating from 50°C to 70°C, see power de-rating on page 3.

\*\*\*PARD is measured with an AC coupling mode, 5cm wires, and in parallel with 0.1 $\mu$ F ceramic capacitor & 47 $\mu$ F electrolytic capacitor.

# PMC Panel Mount Power Supply

## 24V 100W 1 Phase / PMC-24V100W1A□

### Mechanical

Case Chassis / Cover	Aluminium	
Dimensions (L x W x D)	158 x 97 x 38 mm (6.22 x 3.82 x 1.5 inch)	
Unit Weight	0.41 kg (0.90 lb)	
Indicator	Green LED (DC OK)	
Cooling System	Convection	
Terminal	PMC-24V100W1A $\underline{A}$	M3.5 x 7 Pins (Rated 300V/15A)
	PMC-24V100W1A $\underline{J}$	M3.5 x 7 Pins (Rated 300V/20A)
	PMC-24V100W1A $\underline{L}$	M3.5 x 7 Pins (Rated 300V/20A)
Wire	Refer to page 7	
Noise (1 Meter from power supply)	Sound Pressure Level (SPL) < 40dBA	

### Environment

Surrounding Air Temperature	Operating	-10°C to +70°C
	Storage	-25°C to +85°C
Power De-rating	> 50°C de-rate power by 2.5% / °C	
Operating Humidity	5 to 95% RH (Non-Condensing)	
Operating Altitude	3,000 Meters (9,840 ft.)	
Shock Test (Non-Operating)	IEC 60068-2-27, 30G (300m/S <sup>2</sup> ) for a duration of 18ms, 3 times per direction, 18 times in total	
Vibration (Non-Operating)	IEC 60068-2-6, 10Hz to 150Hz @ 50m/S <sup>2</sup> (5G peak); 90 min per axis for all X, Y, Z direction	
Pollution Degree	2	

### Protections

Overvoltage	< 32V ±10%, SELV Output, Hiccup Mode, Non-Latching (Auto-Recovery)
Overload / Overcurrent	> 120% of rated load current, Hiccup Mode, Non-Latching (Auto recovery)
Over Temperature	< 75°C Surrounding Air Temperature @ 100% load, Non-Latching (Auto-recovery).
Short Circuit	Hiccup Mode, Non-Latching (Auto-recovery when the fault is removed).
Degree of Protection	IP20 (PMC-24V100W1AJ)
Protection Against Shock	Class I with PE* connection

\*PE: Primary Earth

### Reliability Data

MTBF	> 700,000 hrs, as per per Telcordia SR-332 I/P: 115Vac, O/P: 100% load, Ta: 25°C
Expected Cap Life Time	10 years (115Vac & 230Vac, 50% load @ 40°C)

# PMC Panel Mount Power Supply

## 24V 100W 1 Phase / PMC-24V100W1A□

### Safety Standards / Directives

Electrical Safety	Nemko Bauart UL/cUL recognized  CCC CB scheme	EN 60950-1 UL 60950-1 and CSA C22.2 No. 60950-1 (File No. E191395) GB4943.1 IEC 60950-1
CE		In conformance with EMC Directive 2004/108/EC and Low Voltage Directive 2006/95/EC
Material and Parts		RoHS Directive 2011/65/EU Compliant
Galvanic Isolation	Input to Output	3.0KVac
	Input to Ground	1.5KVac
	Output to Ground	0.5KVac

### EMC

EMC / Emissions		CISPR 22, EN 55022, FCC Title 47: Class B, GB9254.1
Immunity to		Generic Standard: EN 55024
Electrostatic Discharge	IEC 61000-4-2	Level 4 Criteria A <sup>1)</sup> Air Discharge: 15kV Contact Discharge: 8kV
Radiated Field	IEC 61000-4-3	Level 3 Criteria A <sup>1)</sup> 80MHz-1GHz, 10V/M with 1kHz tone / 80% modulation
Electrical Fast Transient / Burst	IEC 61000-4-4	Level 3 Criteria A <sup>1)</sup> 2kV
Surge	IEC 61000-4-5	Level 3 Criteria A <sup>1)</sup> Common Mode <sup>2)</sup> : 2kV Differential Mode <sup>3)</sup> : 2kV
Conducted	IEC 61000-4-6	Level 3 Criteria A <sup>1)</sup> 150kHz-80MHz, 10Vrms
Power Frequency Magnetic Fields	IEC 61000-4-8	Criteria A <sup>1)</sup> 10A/Meter
Voltage Dips	IEC 61000-4-11	100% dip; 1 cycle (20ms); Self Recoverable
Low Energy Pulse Test (Ring Wave)	IEC 61000-4-12	Level 3 Criteria A <sup>1)</sup> Common Mode <sup>2)</sup> : 2kV Differential Mode <sup>3)</sup> : 1kV
Harmonic Current Emission		IEC/EN 61000-3-2, Class A; GB17625.1
Voltage Fluctuation and Flicker		IEC/EN 61000-3-3

1) Criteria A: Normal performance within the specification limits

2) Asymmetrical: Common mode (Line to earth)

3) Symmetrical: Differential mode (Line to line)

# PMC Panel Mount Power Supply

## 24V 100W 1 Phase / PMC-24V100W1A□

### Block Diagram

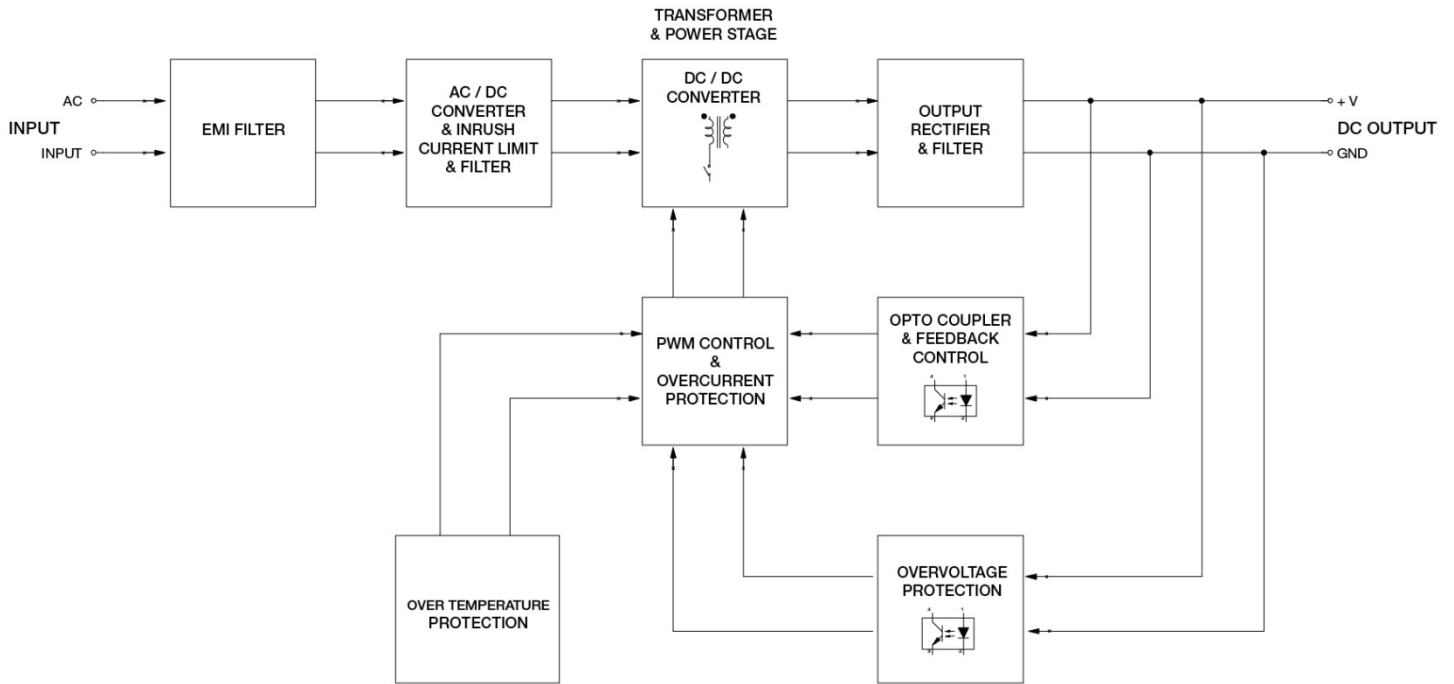

### Device Description

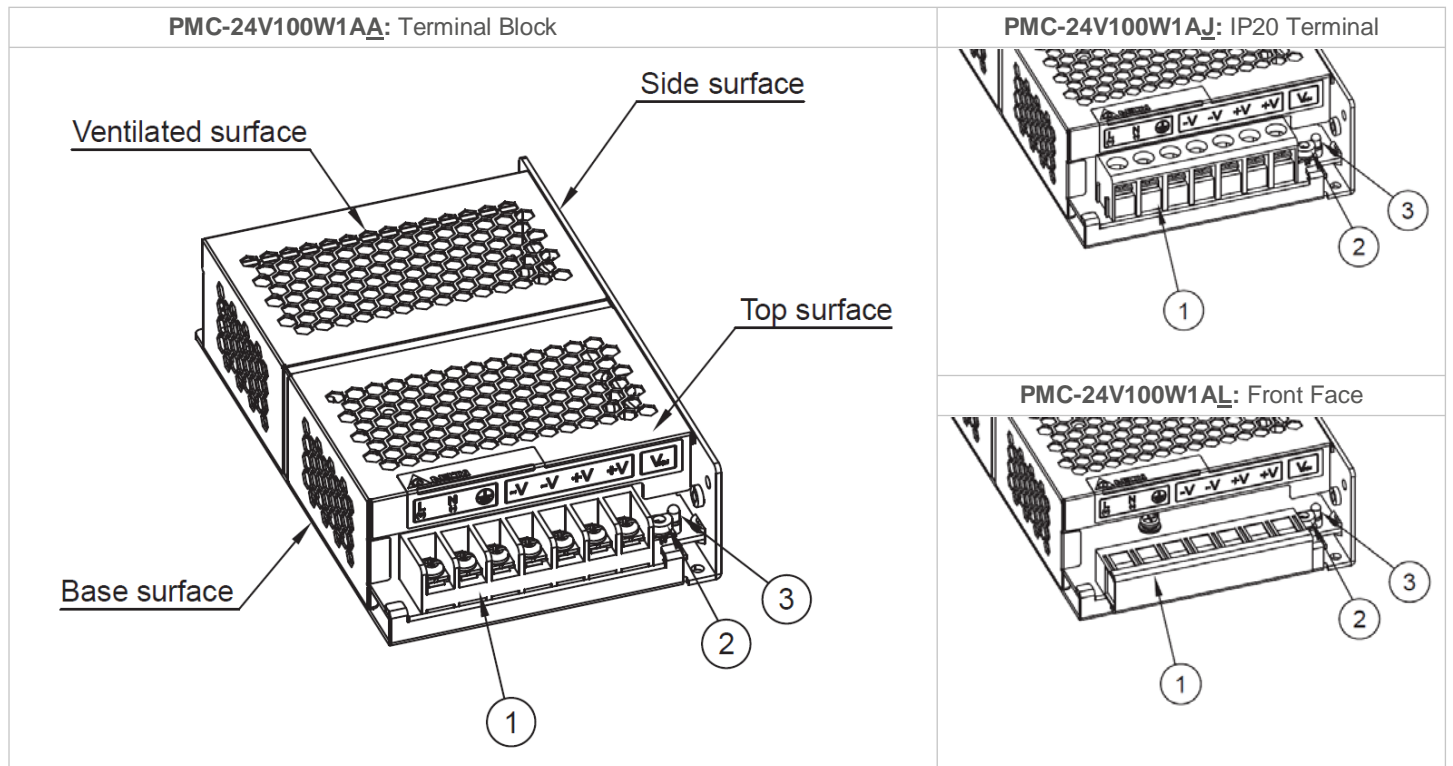

- 1) Input & Output terminal block connector
- 2) DC voltage adjustment potentiometer
- 3) DC OK control LED (Green)

# PMC Panel Mount Power Supply

## 24V 100W 1 Phase / PMC-24V100W1A□

### Dimensions

L x W x D: 158 x 97 x 38 mm (6.22 x 3.82 x 1.5 inch) (PMC-24V100W1AA and PMC-24V100W1AJ)

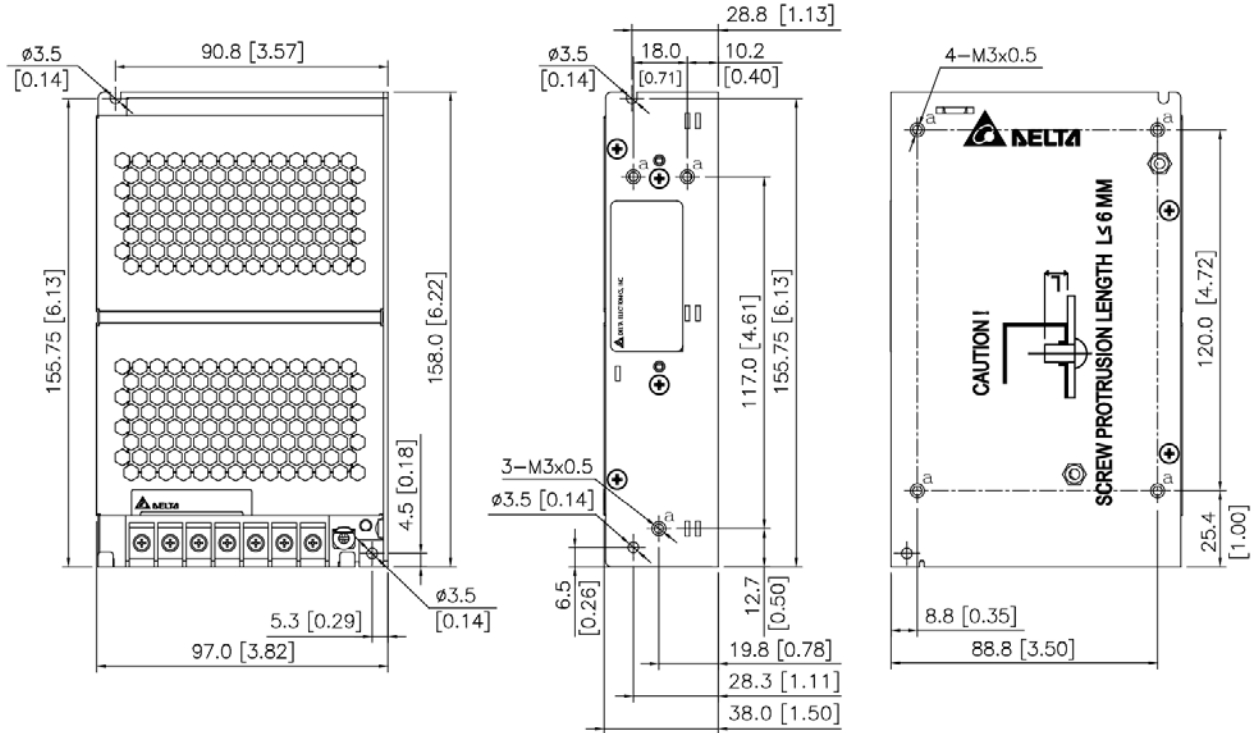

L x W x D: 158 x 97 x 38 mm (6.22 x 3.82 x 1.5 inch) (PMC-24V100W1AL)

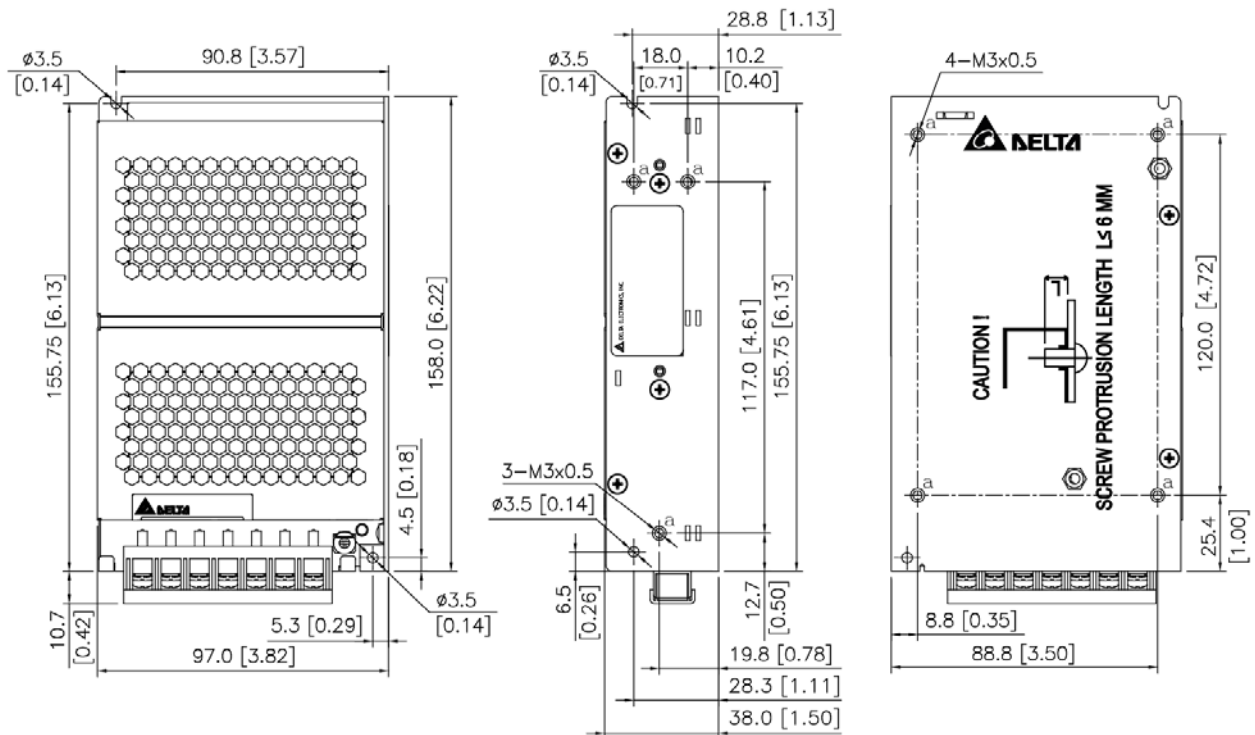

# PMC Panel Mount Power Supply

## 24V 100W 1 Phase / PMC-24V100W1A□

### Engineering Data

#### Output Load De-rating VS Surrounding Air Temperature

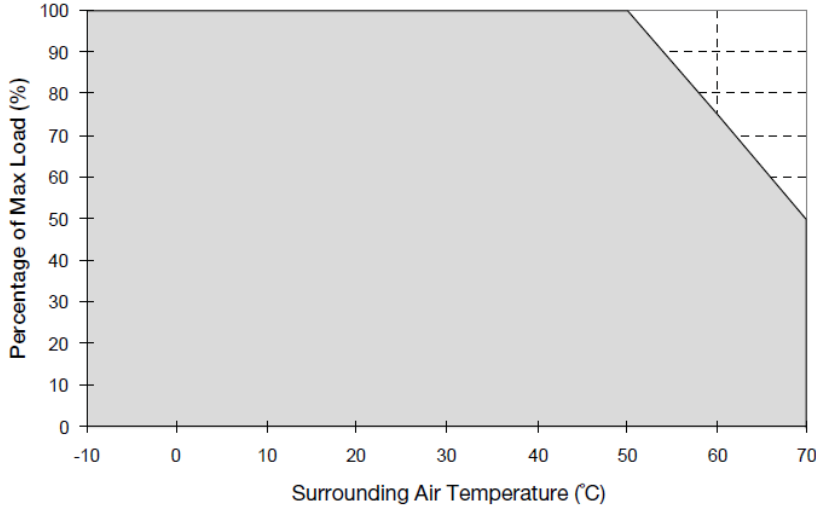
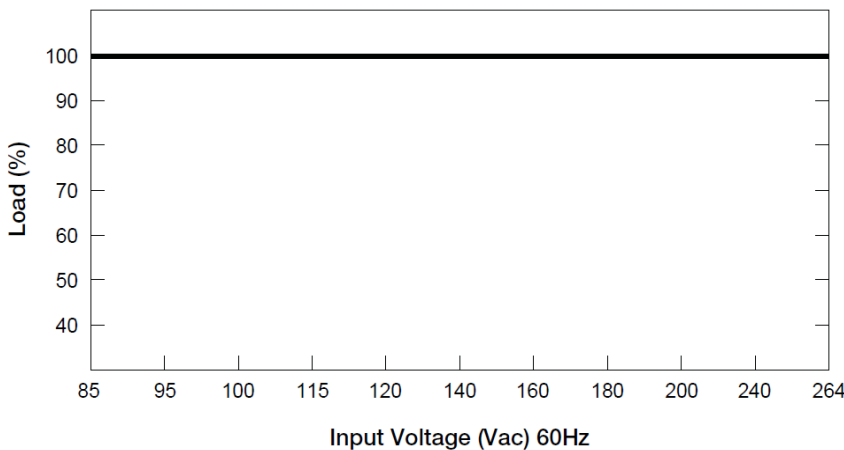

**Fig. 1 De-rating for Vertical and Horizontal Mounting Orientation**  
 > 50°C de-rate power by 2.5% / °C

#### Note

1. Power supply components may degrade, or be damaged, when the power supply is continuously used outside the shaded region, refer to the graph shown in Fig. 1.
2. If the output capacity is not reduced when surrounding air temperature >50°C, the device will run into Over Temperature Protection. When activated, the output voltage will go into bouncing mode and will recover when the surrounding air temperature is lowered or the load is reduced as far as necessary to keep the device in working condition.
3. In order for the device to function in the manner intended, it is also necessary to keep a safety distance of 20mm (0.78 inch) with adjacent units while the device is in operation.
4. Depending on the surrounding air temperature and output load delivered by the power supply, the device can be very hot!
5. If the device has to be mounted in any other orientation, please do contact [info@deltapsu.com](mailto:info@deltapsu.com) for more details.

#### Output Load De-rating VS Input Voltage



- No output power de-rating across the entire input voltage range

# PMC Panel Mount Power Supply

24V 100W 1 Phase / PMC-24V100W1A□

## Assembly & Installation

- Ⓐ Mounting holes for power supply assembly onto the mounting surface.  
The power supply shall be mounted on minimum 2 mounting holes using M3 screw minimum 5mm length.
- Ⓑ This surface belongs to customer's end system or panel where the power supply is mounted.
- Ⓒ Connector

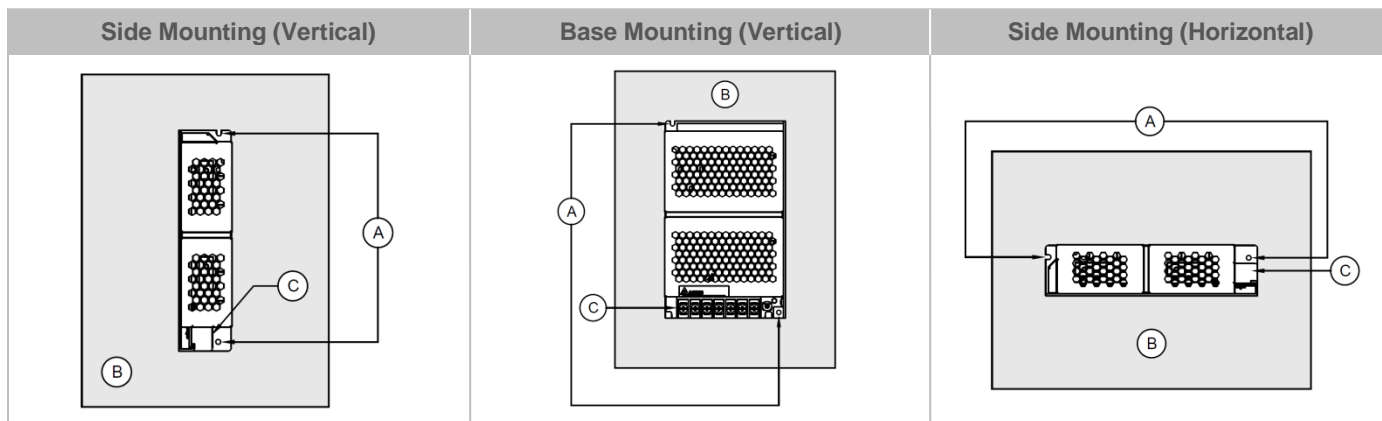

Fig. 2 Mounting Orientation

- Use flexible cable (stranded or solid) with the following sizes:

PMC-24V100W1A <u>A</u>	PMC-24V100W1A <u>J</u>	PMC-24V100W1A <u>L</u>
AWG 22-14	AWG 22-12	AWG 22-12

- The torque at the Connector shall not exceed 13Kgf.cm (11.23 lb.in). The insulation stripping length should not exceed 0.275" or 7mm.

# PMC Panel Mount Power Supply

## 24V 100W 1 Phase / PMC-24V100W1A□

### Installation of Mounting Accessories

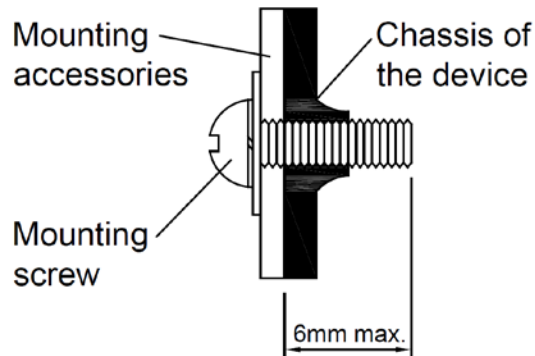

- Only use M3 screw  $\leq$  6mm (0.23 inch) through the base mounting holes. This is to keep a safety distance between the screw and internal components.
- Recommended mounting tightening torque: 4~8Kgf.cm (3.47~6.94 lbf.in).

### Safety Instructions

- To ensure sufficient convection cooling, always maintain a safety distance of  $\geq$  20mm (0.78 inch) from all ventilated surfaces while the device is in operation.
- The device is not recommended to be placed on surface with low thermal conductivity, such as plastics, for example.
- Note that the enclosure of the device can become very hot depending on the ambient temperature and load of the power supply. Do not touch the device while it is in operation or immediately after power is turned OFF. Risk of burning!
- Do not touch the terminals while power is being supplied. Risk of electric shock.
- Prevent any foreign metal, particles or conductors from entering the device through the openings during installation. It may cause: Electric shock; Safety Hazard; Fire; Product failure
- The appliance is not to be used by persons (including children) with reduced physical, sensory or mental capabilities, or lack of experience and knowledge, unless they have been given supervision or instruction.
- Warning: When connecting the device, secure Earth connection before connecting L and N. When disconnecting the device, remove L and N connections before removing the Earth connection.
- The device is earthed and must be inaccessible.

# PMC Panel Mount Power Supply

## 24V 100W 1 Phase / PMC-24V100W1A□

### Functions

#### Start-up Time

The time required for the output voltage to reach 90% of its final steady state set value, after the input voltage is applied.

#### Rise Time

The time required for the output voltage to change from 10% to 90% of its final steady state set value.

#### Hold-up Time

Time between the collapse of the AC input voltage, and the output falling to 95% of its steady state set value.

#### ■ Graph illustrating the Start-up Time, Rise Time, and Hold-up Time

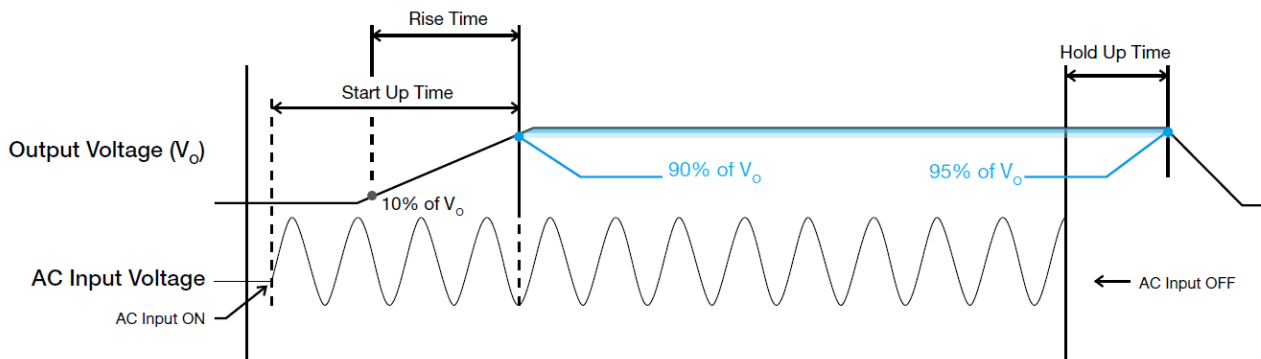

#### Inrush Current

Inrush current is the peak, instantaneous, input current measured and, occurs when the input voltage is first applied. For AC input voltages, the maximum peak value of inrush current will occur during the first half cycle of the applied AC voltage. This peak value decreases exponentially during subsequent cycles of AC voltage.

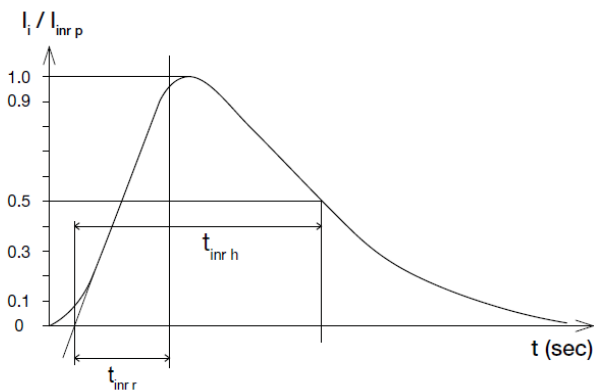

#### Dynamic Response

The power supply output voltage will remain within  $\pm 5\%$  of its steady state value, when subjected to a dynamic load from 0% to 100% of its rated current.

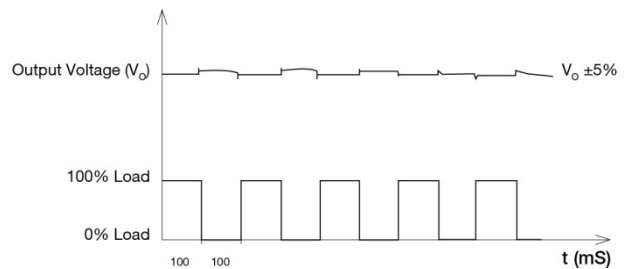

# PMC Panel Mount Power Supply

24V 100W 1 Phase / PMC-24V100W1A□

## Overload & Overcurrent Protections (Auto-Recovery)

The power supply's Overload (OLP) and Overcurrent (OCP) Protections will be activated when output current exceeds 120% of  $I_O$  (Max load). In such occurrence, the  $V_O$  will start to droop and once the power supply has reached its maximum power limit, the protection is activated and the power supply will go into "Hiccup mode" (Auto-Recovery). The power supply will recover once the fault condition of the OLP and OCP is removed and  $I_O$  is back within the specifications.

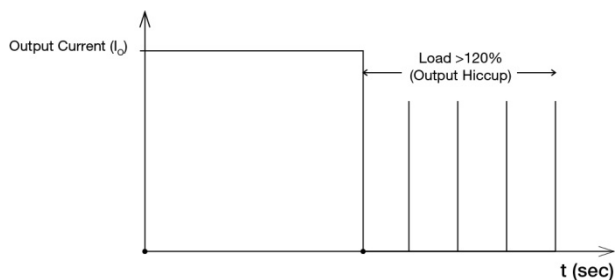

It is not recommended to prolong the duration of  $I_O$  when it is <120% but >100%, since it may cause damage to the PSU.

## Short Circuit Protection (Auto-Recovery)

The power supply's output OLP/OCP function also provides protection against short circuits. When a short circuit is applied, the output current will operate in "Hiccup mode", as shown in the illustration in the OLP/OCP section on this page. The power supply will return to normal operation after the short circuit is removed.

## Overvoltage Protection (Auto-Recovery)

The power supply's overvoltage circuit will be activated when its internal feedback circuit fails. The output voltage shall not exceed its specifications defined on Page 3 under "Protections".

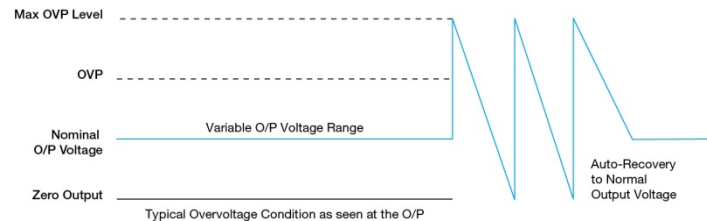

## Over Temperature Protection (Auto-Recovery)

As described in load de-rating section, the power supply also has Over Temperature Protection (OTP). In the event of a higher operating temperature at 100% load, the power supply will run into OTP when the operating temperature is beyond what is recommended in the de-rating graph. When activated, the output voltage will go into bouncing mode until the temperature drops to its normal operating temperature as recommended in the de-rating graph.

# PMC Panel Mount Power Supply

## 24V 100W 1 Phase / PMC-24V100W1A□

### Operating Mode

#### ■ Redundant Operation

In order to ensure proper redundant operation for the power supply units (PSUs), the output voltage difference between the two units must be kept at 0.45~0.50V for these 24V supplies. Follow simple steps given below to set them up for the redundant operation:

##### Step 1.

Measure output voltage of PSU 1 and PSU 2. If PSU 1 is the master unit, then  $V_O$  of PSU 1 must be higher than PSU 2. In order to set the output voltage, individually connect each power supply to 50% of rated load at any line voltage from 85-264Vac, and set the PSU 1 and PSU 2 output voltage.

##### Step 2.

Connect the power supply units PSU 1 and PSU 2 to  $V_{in1}$  &  $V_{in2}$ , respectively, of the DRR-20N (or 20A) module shown on the right of above diagram.

##### Step 3.

Connect the system load to  $V_{out}$ . Please note that output voltage  $V_{out}$  from DRR module will be =  $V_O$  (output voltage of power supply) –  $V_{drop}^*$  (in DRR module).

\* $V_{drop}$  will vary from 0.60V to 0.90V (Typical 0.65V) depending on the load current and surrounding air temperature.

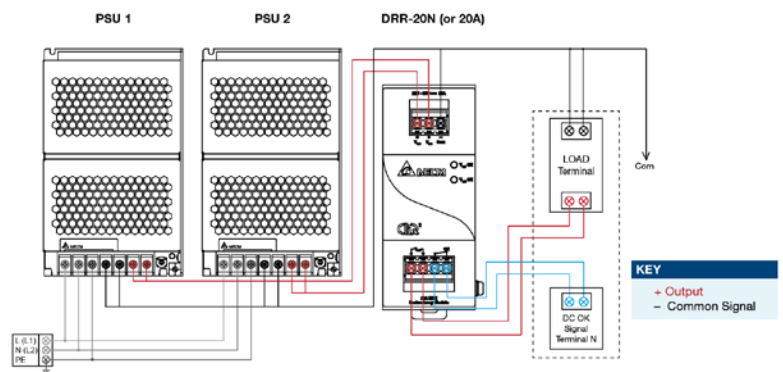

Fig. 3 Redundancy Operation Connection Diagram

#### ■ Parallel Operation

The power supply units (PSUs) can also be used for parallel operation in order to increase the output power. The difference in output voltage between the two units must be kept to within 25mV of each other. This difference must be verified with the same output load connected independently to each unit.

Parameters such as EMI, inrush current, leakage current, PARD, start up time will be different from those on the datasheet, when two units are connected in parallel. The user will need to verify that any differences will still allow the two power supplies connected in parallel will work properly in their product/application.

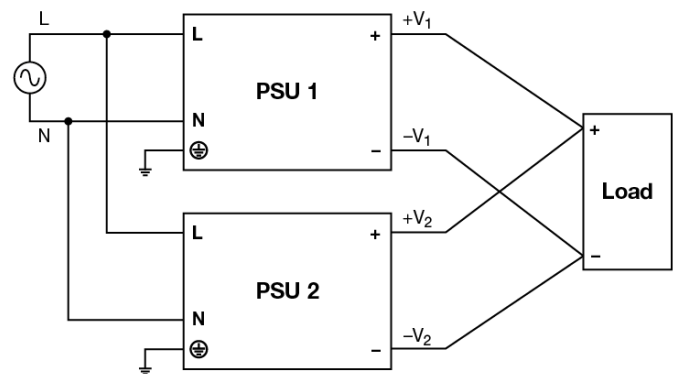

Fig. 4 Parallel Operation Connection Diagram

# PMC Panel Mount Power Supply

## 24V 100W 1 Phase / PMC-24V100W1A□

### Others

Delta RoHS Compliant



#### Restriction of the usage of hazardous substances

The European directive 2011/65/EU limits the maximum impurity level of homogeneous materials such as lead, mercury, cadmium, chrome, polybrominated flame retardants PBB and PBDE for the use in electrical and electronic equipment. RoHS is the abbreviation for "Restriction of the use of certain hazardous substances in electrical and electronic equipment".

This product conforms to this standard.

PFC – Norm EN 61000-3-2

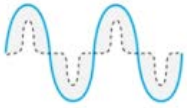

#### Line Current harmonic

Typically, the input current waveform is not sinusoidal due to the periodical peak charging of the input capacitor. In industrial environment, complying with EN 61000-3-2 is only necessary under special conditions. Complying to this standard can have some technical drawbacks, such as lower efficiency as well as some commercial aspects such as higher purchasing costs. Frequently, the user does not profit from fulfilling this standard, therefore, it is important to know whether it is mandatory to meet this standard for a specific application.

This product conforms to this standard.

# Mouser Electronics

Authorized Distributor

Click to View Pricing, Inventory, Delivery & Lifecycle Information:

[Delta Electronics:](#)

[PMC-24V100W1AA](#) [PMC-24V100W1AJ](#)